

**Push Button Valve (PBV) for Pressure Gauges
Installation Instructions**

SPECIFICATIONS

Push Button Valve The push button valve (PBV) replaces a manual ball valve when mounting pressure gauges to the gas piping. When manually actuated by pushing a spring return button, the pressure on the gauge can be read. Once released, the PBV automatically closes, and the pressure on the gauge is automatically removed. The PBV increases the life of the pressure gauge and protects the gauge from pressure surges.

Body size

1/4" NPT; part number 242-645
Rp 1/2"; part number 033-621, and requires metal seal p/n 241 961 (10 pcs).

Gases

Natural gas, propane, butane; & noncorrosive gases

Maximum Operating Pressure

70 PSI (5 Bar)

Temperature

Ambient: -5°F to +145°F; (-20°C to +60°C)
Fluid: -32°F to +155°F; (-0°C to +70°C)

Approvals

NPT threaded: DVGW VP 308 "Gas Shutoff Valves for Pressure Gauges"
Rp threaded: CE 0085 AQ 0985 to EU directive EU/90/396/EWG



Push Button Valve

DIMENSIONS

1/4" NPT Version

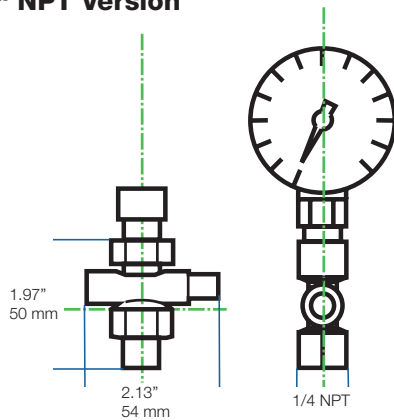

Rp 1/2" Version

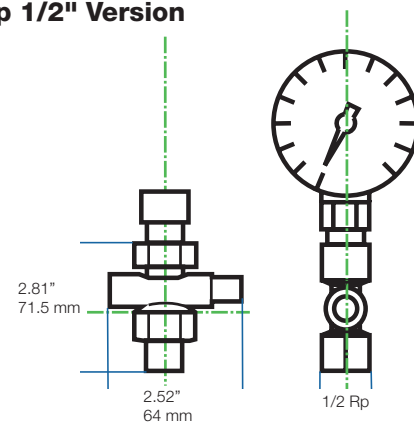

ATTENTION

- Read these instructions carefully.
- Failure to follow them and/or improper installation may cause explosion, property damage and injuries.
- Installation must be done with the supervision of a licensed burner technician.
- Check the ratings in the specifications to make sure that they are suitable for your application.
- Never perform work if gas pressure or power is applied, or in the presence of an open flame.
- Once installed, perform a complete checkout including leak testing.
- Verify proper operation after servicing.
- The system must be installed, used, and maintained to meet all applicable national and local code requirements such as but not limited to NFPA 86, CSD-1, NFPA 85, or CSA B149.3.

OPERATION AND MOUNTING PBV

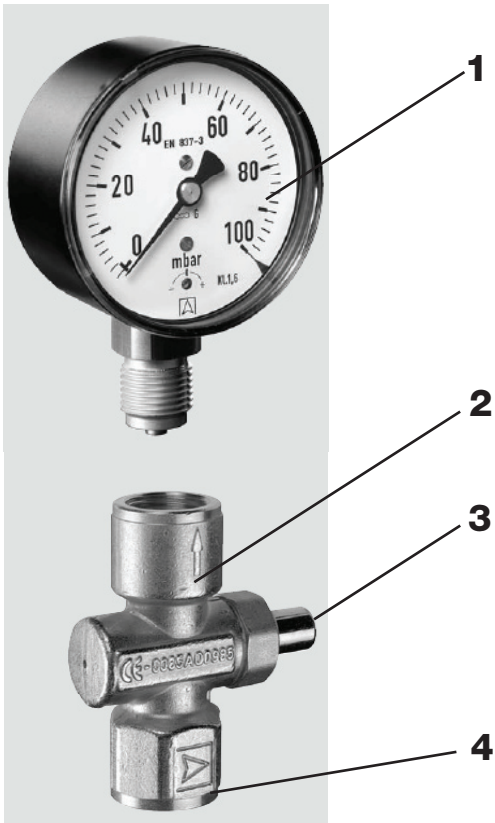

- 1) Pressure Gauge
- 2) Push Button Valve
- 3) Push to read gauge pressure, and release to remove pressure from gauge
- 4) Pipe connection to gas line

Recommended Procedure for Rp 1/2" PBV

- Use new, properly reamed and threaded pipe free of chips and visible defects.
- Install the PBV with the gas flow matching the direction indicated by the arrow on the casting.

⚠ Do not apply pipe sealant to the outlet threads of the Rp 1/2" PBV. The pressure tight connection is achieved by a metal seal (see below).

- The pressure tight connection between the Rp 1/2" PBV and the pressure gauge is a metal seal (part number 227-125). Place the metal seal into the outlet side of the PBV, and mount the 1/2" pressure gauge. Turn the gauge enough so that it engages and compresses the metal seal, which should be about 1/2 to 1 full turn beyond a snug fit.

⚠ Do not re-use the metal seal if the gauge is removed from the PBV. Re-using a seal will likely result in gas leak while reading the pressure gauge.

Recommended Procedure for 1/4" NPT PBV

- Use new, properly reamed and threaded pipe free of chips and visible defects.
- Install the PBV with the gas flow matching the direction indicated by the arrow on the casting.
- Apply a moderate amount of proper pipe sealant to the male threads of the NPT pipe, and thread the pipe into the inlet side of the PBV. Do not thread pipe too far. Cracks resulting in leaks or valve malfunction may result from excess pipe in the valve body.

⚠ It is important that pipe sealant does not fall into and plug the outlet of the valve. If the outlet gets plugged, the PBV will not work properly.

- Apply a much smaller amount of proper pipe sealant to the male threads of the pressure gauge.